

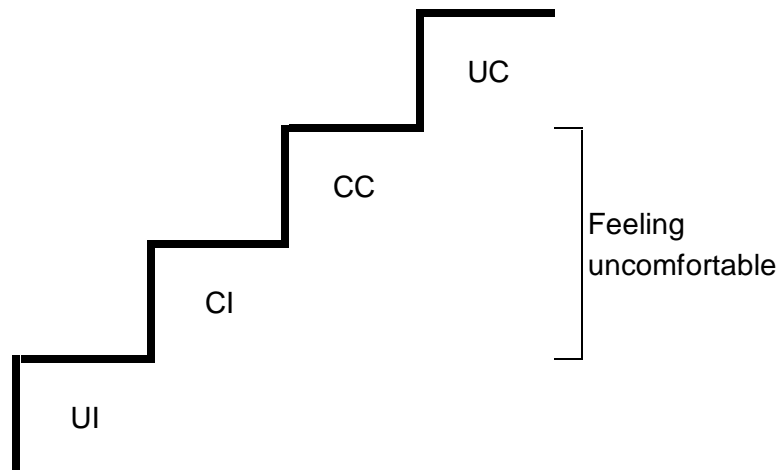

4 Steps to learning



| | |
|----|--------------------------|
| UI | Unconscious incompetence |
| CI | Consious incompetence |
| CC | Consious competence |
| UC | Unconscious competence |

There are 4 steps to learning.

Example: Learning to drive a car

| | | |
|--------|----|--|
| Step 1 | UI | You have not driven a car before and have no concept of the skills or risks |
| Step 2 | CI | You begin to learn and understand the skills required and identify the risks |
| Step 3 | CC | You are driving a car and you are self consious and aware of each move |
| Step 4 | UC | You reach the stage when you are driving a car with ease and confidence |

www.thecomfortzoneuk.com